

# Design and Simulation of Permanent Magnet Synchronous Motor Drive by Using Fuzzy Logic Controller

G.Gurumurthy<sup>1</sup>, P.Suneel Kumar<sup>2</sup>, D.Rajesh Reddy<sup>3</sup>

Lecturer, EEE, JNTUACE, Pulivendula, India<sup>1</sup>

Lecturer, EEE, JNTUACE, Pulivendula, India<sup>2</sup>

Assistant Professor, EEE, NECG, Gudur, India<sup>3</sup>

**Abstract:** To improve the dynamic performances of the permanent magnet synchronous motor (PMSM) drive, a novel implementation of speed controller based on adaptive fuzzy logic is presented in this paper. Using the output of the fuzzy speed controller (FC), the quadrature axis current reference value can be obtained. At the same time, the outputs of the current controller can be corrected by the disturbance voltage observer's outputs. Results of simulation are provided to demonstrate the effectiveness of the proposed scheme under the occurrence of parameter variations and external disturbance.

**Keywords:** PMSM, fuzzy, speed controller, simulation.

## I. INTRODUCTION

For vector controlled PMSM drives, the conventional speed controller such as proportional integral (PI) controller can't give satisfactory performance when the running conditions changed [1, 2]. Nowadays, some adaptive controllers have been applied in both ac and dc motor drive. Such as model reference adaptive controller (MRAC) [3] and sliding model controller (SMC) [4], etc. all the types of controllers can improve the performance of the motor drive system. However, they are usually based on the parameters and structure of the system model. It will lead to complex computation when the system model is uncertainty.

Fuzzy controllers have been applied to many industrial fields, and it does not need mathematical model of the controlled system. In [5], the fuzzy controller instead of the traditional hysteresis controller is proposed in direct torque controlled PMSM drives, the appropriate voltage vector can be selected according to torque and flux settings the ability to deal with uncertain information of the fuzzy logic. In [6], a scheme of establishing fuzzy speed controller is introduced. They all achieve the satisfactory results up to some extent.

In this paper, the conventional PI speed controller is replaced by the fuzzy controller, when the parameters of PMSM are changed, voltage compensation term can be obtained by a disturbance voltage observer. It combines the capability of fuzzy reasoning in handling uncertain information and the ability to compensate of the disturbance voltage observer on-line. The proposed control scheme has been testified by simulation, the results indicate the PMSM drive with the adaptive fuzzy controller will have the ability of

quick recovery of the speed from any disturbances and parameters variation. Accordingly, the proposed PMSM drive will have better dynamic performances and robustness.

## II. DISTURBANCE VOLTAGE OBSERVER OF THE PMSM

The vector control technique was firstly proposed for induction motors, while it was applied to PMSM later. Its basic principle is to decouple the stator current to get direct axis (d-axis) and quadrature axis (q-axis) components. The vector control strategy is formulated in the synchronously rotating reference frame. An efficient control strategy of the vector control technique is to make the d-axis current  $i_d$  zero so that the torque becomes dependent only on q-axis current.

The stator voltage equations of a PM synchronous motor in the synchronously rotating reference frame are described as follows:

$$U_d = R_s i_d + L_d \dot{i}_d - L_q \omega_r i_q \quad (1)$$

$$U_q = R_s i_q + L_q \dot{i}_q + L_d \omega_r i_d + \psi_f \omega_r$$

Where

$U_d$  d-axis voltage in synchronous frame, [V];

$U_q$  q-axis voltage in synchronous frame, [V];

$R_s$  motor phase resistance, [Q];

$L_d$  d-axis inductance, [H];

$L_q$  q-axis inductance, [H];

$i_d$  d-axis current in synchronous frame, [A];

$i_q$  q-axis current in synchronous frame, [A];

$\omega_r$  motor electrical angular velocity, [Rad/s];

$\psi_d$  d-axis flux linkage in synchronous frame, [Wb];

$\psi_q$  q-axis flux linkage in synchronous frame, [Wb];

$\Psi_f$  PM flux linkage in synchronous frame, [Wb]. Accordingly, the discrete-time equation can be Obtained as follows [7,8].

$$U_d(n) = R_s i_d(n) + \frac{L_d}{T} [i_d(n) - i_d(n-1)] - L_q W_r i_q(n) \quad (2)$$

$$U_q(n) = R_s i_q(n) + \frac{L_q}{T} [i_q(n) - i_q(n-1)] + L_d W_r i_d(n) + \Psi_f W_r \quad (3)$$

Where T is the sampling period.

When the parameters of PMSM vary during the operation, it will cause the disturbances  $f_d(n)$  and  $f_q(n)$ , giving [7].

$$f_d(n) = \Delta R_s i_d(n) + \frac{\Delta L_d}{T} [i_d(n) - i_d(n-1)] - \Delta L_q W_r i_q(n) \quad (4)$$

$$f_q(n) = \Delta R_s i_q(n) + \frac{\Delta L_q}{T} [i_q(n) - i_q(n-1)] + \Delta L_d W_r i_d(n) + \Delta \Psi_f W_r \quad (5)$$

Where  $\Delta R_s = R_s - R_{s0}$ ,  $\Delta L_d = L_d - L_{d0}$ ,  $\Delta L_q = L_q - L_{q0}$ ,  $\Delta \Psi_f = \Psi_f - \Psi_{f0}$  and subscript "0" denotes the nominal value.

The steady-state response of the predictive control can be effectively improved by using a simple time delay control approach. In the time delay control, it is considered that the values of  $f_d(t)$ ,  $f_q(t)$  and at the present time are very close to those at time  $t - \tau$  ( $\tau = LT$ ) in the past for a small time  $\tau$  delay, and can be expressed when  $L=1$  is chosen as follows [8].

$$f_d(n) = f_d(n-1) \quad (6)$$

$$f_q(n) = f_q(n-1)$$

By approximating the disturbances at the present time with those of (n-1)th time step and using (5) and (6), the simple estimates for the disturbances can be derived as follows [7]

$$\hat{f}_d(n) \approx \hat{f}_d(n) = U_d(n) - [R_{s0} i_d(n) + \frac{L_{d0}}{T} (i_d(n) - i_q(n)) - L_{q0} W_r i_q(n)] \quad (7)$$

$$\hat{f}_q(n) \approx \hat{f}_q(n) = U_q(n) - [R_{s0} i_q(n) + \frac{L_{q0}}{T} (i_d(n) - i_q(n)) + L_{d0} W_r i_d(n) + \Psi_{f0} W_r(n)] \quad (8)$$

Taking in to account equation (7) and (8) contain high-order harmonic components, in the application process, a low-pass filter is needed. Therefore, disturbances voltage caused by the parameters changes can be expressed as [7].

$$\hat{f}_{df}(n) = \frac{2-aT}{2+aT} \hat{f}_{df}(n-1) + \frac{aT}{2+aT} [\hat{f}_d(n) + \hat{f}_{df}(n-1)] \quad (9)$$

$$\hat{f}_{qf}(n) = \frac{2-aT}{2+aT} \hat{f}_{qf}(n-1) + \frac{aT}{2+aT} [\hat{f}_q(n) + \hat{f}_{qf}(n-1)] \quad (10)$$

Under the occurrence of parameter variations and external disturbance, the disturbances voltage, by which  $U_d^*$  and  $U_q^*$  will be revised on-line, can be calculated from equation (9) and (10).

### III. STRUCTURE OF FUZZY SPEED CONTROLLER

Most of the PMSM controllers for industrial applications adopt a fixed-gain PI scheme. This fixed-gain scheme may work fine under certain operating conditions, but degrades its performance under other operating conditions. Moreover, suitable PI gains usually obtained using time-consuming trial-and-error methods to increase the performances of PMSM drive, an adaptive speed controller

base on fuzzy logic is proposed. The block diagram of the proposed scheme is illustrated in figure 1.

The output of the fuzzy speed controller is the reference value of quadrature axis current  $i_q^*$  and the inputs are can be expressed as follows respectively.

$$e_{s1} = w_r^*(n) - w_r(n)$$

$$e_{s2} = w_r(n-1) - w_r(n)$$

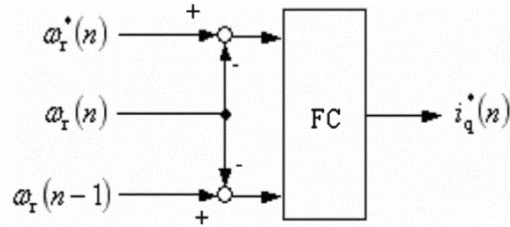

Figure 1. Membership function of FC

The inputs are the estimate value of the disturbance voltage observer  $\hat{f}_{df}(n)$  and  $\hat{f}_{qf}(n)$ . The universe of all input and output variables are normalized to [-1 1]. The fuzzy membership functions of the input variables and output variable of the fuzzy controller as shown in figure 2. And the corresponding fuzzy logic-table showed in table 1 respectively. In real time implementation, using the reference speed and the actual speed we can calculate  $e_{s1}$  and  $e_{s2}$  and the new reference values of the quadrature axis current  $i_q^*$  can be obtained from the speed fuzzy controller. Once the parameter variation and an external disturbance appear, the reference values of quadrature axis and direct axis will be revised by the output of the disturbance voltage observer.

Table 1. The fuzzy logic rule

$e_{s2} \backslash e_{s1}$	NB	NM	NS	ZO	PS	PM	PB
NB	NB	NB	NM	NM	NS	ZO	ZO
NM	NB	NB	NM	NS	NS	ZO	PS
NS	NM	NM	NM	NS	ZO	PS	PS
ZO	NM	NM	NS	ZO	PS	PM	PM
PS	NS	NS	ZO	PS	PS	PM	PM
PM	NS	ZO	PS	PM	PM	PM	PB
PB	ZO	ZO	PM	PM	PM	PB	PB

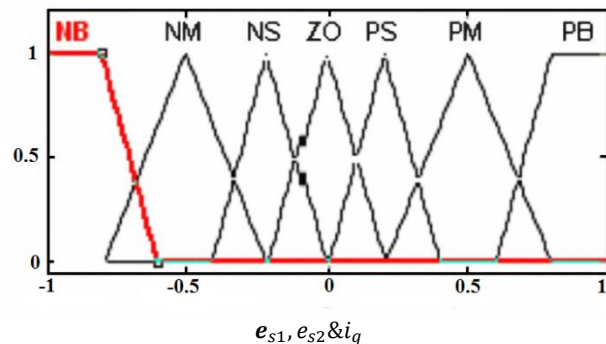

Figure 2. The membership function

### IV. RESULTS OF SIMULATION

A block diagram of the proposed PMSM drive is shown in Fig 3. The parameters of PMSM are shown in Table 2. And the availability is confirmed by computer simulations. The simulation conditions are:  $J=1.5J_0$ ,  $R_s = 2R_{s0}$ ,  $\Psi_f = 0.8\Psi_{f0}$ ,  $L_d =$

$1.3L_{d0}$ ,  $L_q = 1.3L_{q0}$ ,  $n^*=1800\text{r/min}$ ,  $T_z=100\text{ N.m}$ . the results under the PI speed controller and the proposed scheme are shown in Fig.4 and Fig.5 respectively.

Under the above-mentioned simulation conditions, Fig. 4 and Fig. 5 show that the dynamic response performances of the PMSM drive based on the proposed scheme has been improved to some extent compared with the system based on the conventional PI speed controller.

TABLE 2. Parameters of PMSM

Rated voltage UN(V)	440
Rated speed(r/min)	1800
Rated current (A)	90
Stator resistance Rs ( Q )	0.06
d-axis stator inductance Ld (mH)	2.562
q-axis stator inductance Lq (mH)	3.080
Rotor flux linkage Ijff (Wb)	0.69

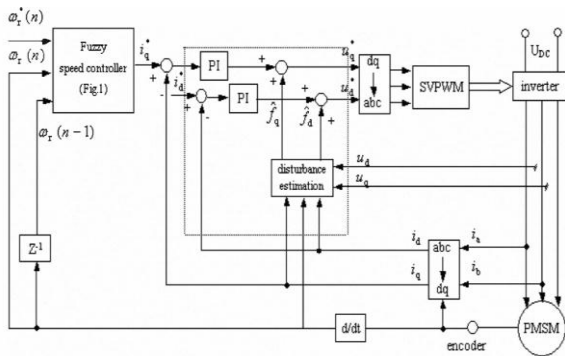
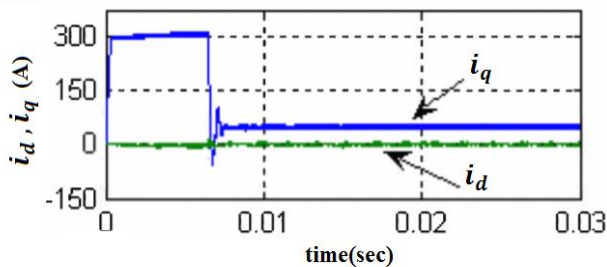
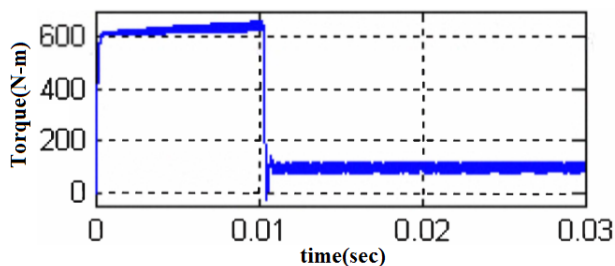

Figure 3.Overall block diagram of PMSM drive based on proposed control scheme.



(a) Speed response.



(b) Torque response

Figure 4. Results of PMSM control drive based on PI speed controller

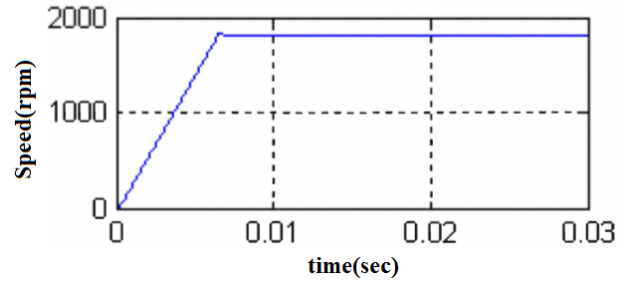

(a) Speed response

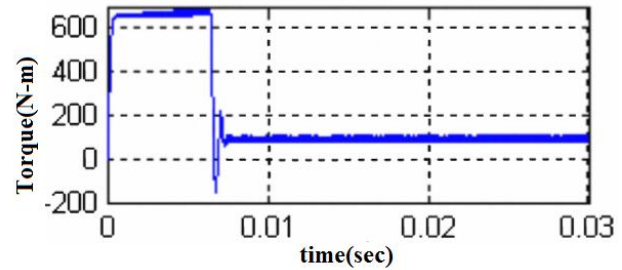

(b)Torque response

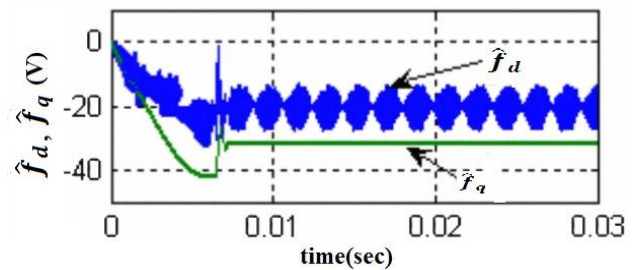

(c) Disturbance voltage observer values

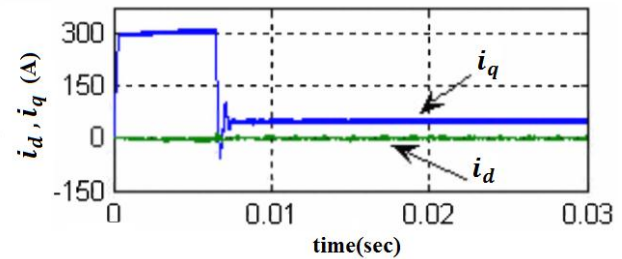

(d) Current response

Figure 5. Results of PMSM based on proposed scheme

## V.CONCLUSION

In this paper, a vector control scheme with the fuzzy speed controller with the disturbance voltage observer for the PMSM has been presented. It combines the capability of fuzzy reasoning in handling uncertain information and the ability to compensate of the disturbance voltage observer on-line. The results of simulation have shown that the PMSM drive with the proposed control scheme has the merits of simple structure, robustness, quick tracking performance.

## REFERENCES

- [1] Yang Vi, D. Mahinda Vilathgamuwa, M. A. Rahman, "Implementation of an Artificial-Neural-Network-Based Real-Time Adaptive Controller for an Interior Permanent-Magnet Motor Drive,"IEEE Transactions on Energy Conversion, vol. 2, 2003, pp. 96-104.
- [2] Faa-Jeng Lin, Chih-Hong Lin, " A Permanent-Magnet Synchronous Motor Servo Drive Using Self-Constructing Fuzzy Neural Network Controller", IEEE Transactions on Energy Conversion, 2004,

- pp.66-72.
- [3] H. Naitoh, S. Tadakuma, "Microprocessor Based Adjustable Speed dc Motor Drives Using Model Reference Adaptive Control," IEEE Transactions on Industry Applications, vol. 2, 1987, pp.313-318.
  - [4] Y. Dote, R. G. Hoft, "Microprocessor Based Sliding Mode Controller for dc Motor Drives", IEEE/IAS Annual Meeting, 1980, pp.641-645.
  - [5] Dan Sun and Yikang He, "Fuzzy logic direct torque control for permanent magnet synchronous motors," Proceedings of the 5th world congress on intelligent control and automation, Hangzhou, P.R. China, June 2004, pp. 4401-4405.
  - [6] Jun Liu and Pusheng Wu, "Application of fuzzy control in direct Torque control of permanent magnet synchronous motor," Proceedings of the 5th world congress on intelligent control and automation, Hangzhou, P. R. China, June 2004, pp. 4573-4576.
  - [7] Kyeong-Hwa Kim, Myung-Joong Youn. A simple and robust digital current control technique of a PM synchronous motor using time delay control approach. IEEE Transactions on power electronics, vol. 16, pp.72-82, 2001.
  - [8] K H Kim. Design and performance comparison of a stationary frame digital current control for a PM synchronous motor. IEEE proc.electr.power appl. vol. 150, 2003, pp. 357-364.

### BIOGRAPHIES

**G.GURUMURTHY** was born in Kadapa, India, in 1989. He received the B.Tech degree in electrical and electronics engineering from JNTU Anantapur and M.Tech degree in control systems from JNTU Hyderabad, India in 2010 and 2013, respectively. He worked as an assistant professor at St. Peters engineering college from 2013-2014. He is currently working as a Lecturer at the JNTUACEP pulivendula, India.

**P.SUNEEL KUMAR** is a Lecturer at the JNTUACE pulivendula, Andhra Pradesh. He received the B.Tech. Degree in electrical engineering from Nagarjuna University in 2010. He received M.Tech Degree from JNTU anantapur in the year 2014. He worked at JNTUACE pulivendula from 2014-2015.

**RAJAREDDY DUVVURU** received his B.Tech in electrical engineering in 2009 from the NECG, JNTUA Anantapur. His received M.Tech in electrical power engineering in 2011 from the SITAMS, JNTUA Anantapur. He is pursuing Ph.D. in JNTUA Anantapur. His presently working as Lecturer in JNTUACEP Pulivendula, Kadapa. His interest area in power quality and FACTS controllers.